

Modernage Public School & College, Abbottabad
Homework for Winter Break Class 7
Session 2024 – 25

Dear Parents/Guardians

Finally, Winter is here, signaling the end of the Academic session 2023 and start of a winter break.

We take great pleasure in announcing the successful culmination of the academic session 2023. Observing the continuous development and advancement of your child has been a source of immense satisfaction. To foster ongoing engagement with education during the holiday period, we are providing a comprehensive work pack comprising a multitude of enjoyable tasks and intellectually stimulating activities. Thank you for being an integral partner in your child's education. We eagerly anticipate another year of mutual growth and learning.

Dear Modernites!

Reflect on the achievements and lessons learned during the previous academic session. Complete the assigned exercises in your respective subjects, embracing the knowledge gained. Take a moment to chill and recharge during this winter break. Use the new year as a fresh start for academic goals and personal growth. Ensure neatness and organization in your work. We hope that you have cheerful and safe Winter vacation with your families.

The school will remain closed for winter vacation from **Sun, 24th December, 2023 till Sun 03rd March, 2024** and reopen on **Mon 04th March, 2024 In Sha Allah.**

Submit the completed assignment till 10th March 2024.

Looking forward to your cooperation. A copy of this homework is also available at the official webpage www.maps.edu.pk, the portal and app of Modernage.

Best Regards

Academic Coordinator

Happy New Year.

Note: Certificates will be awarded for extra ordinary efforts and complete homework. Please use loose sheets for your assignments.

Note for the Students:

1. Read at least 2 story books of English and Urdu to enhance the reading skills and write the central idea and review of them. Write at least 50 new words from the story books that you have read.
2. Recite any poem with action from your book, make a video and share with your teacher.
4. Take a few pictures from newspapers or magazines about economic instability. Cut and paste those pictures on blank sheets. Write suggestions about what will be your contribution towards resolving those issues.
5. Improve your listening, speaking, reading and writing skills by practicing the worksheets with related audio. Use the provided link for practice <https://learnenglish.britishcouncil.org/skills> .

Q.1

(10)

THE BRAIN

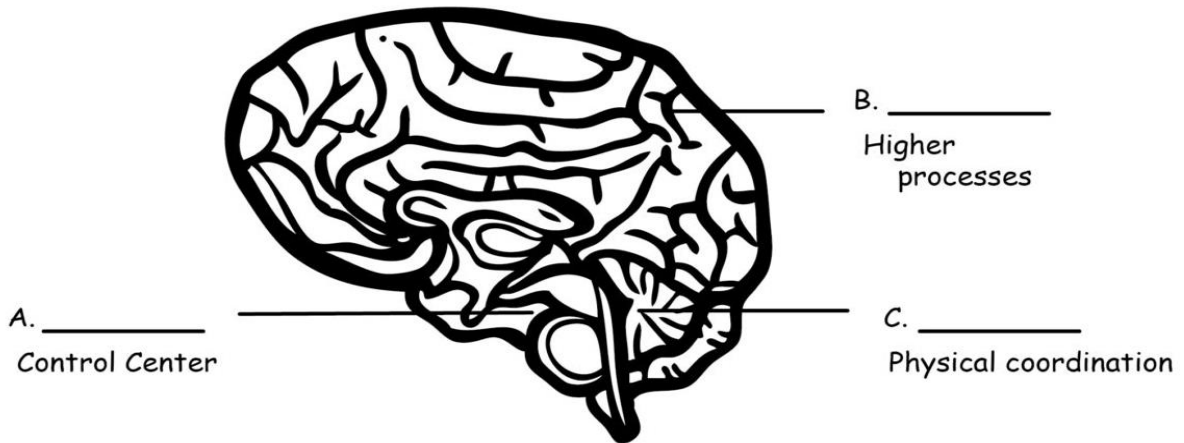

Identify the three major parts of the brain indicated on the diagram. Write the name of each part in the appropriate space on the diagram above and in the chart below. Briefly describe the function of each in the space indicated.

NAME	FUNCTION
A. _____	_____
B. _____	_____
C. _____	_____

Name the parts of the brain responsible for coordinating or controlling each activity or condition listed below.

NAME	FUNCTION
1. Tasting a hamburger	_____
2. Artistic ability	_____
3. Kicking a soccer ball	_____
4. Rate of breathing	_____
5. Tying your shoes	_____

Q.2

(10)

The Carbon Cycle

Label the numbered boxes correctly with the following:

Respiration by animals

Feeding

Decomposition

Death and waste

No decomposition

Combustion

Respiration by plants

Photosynthesis

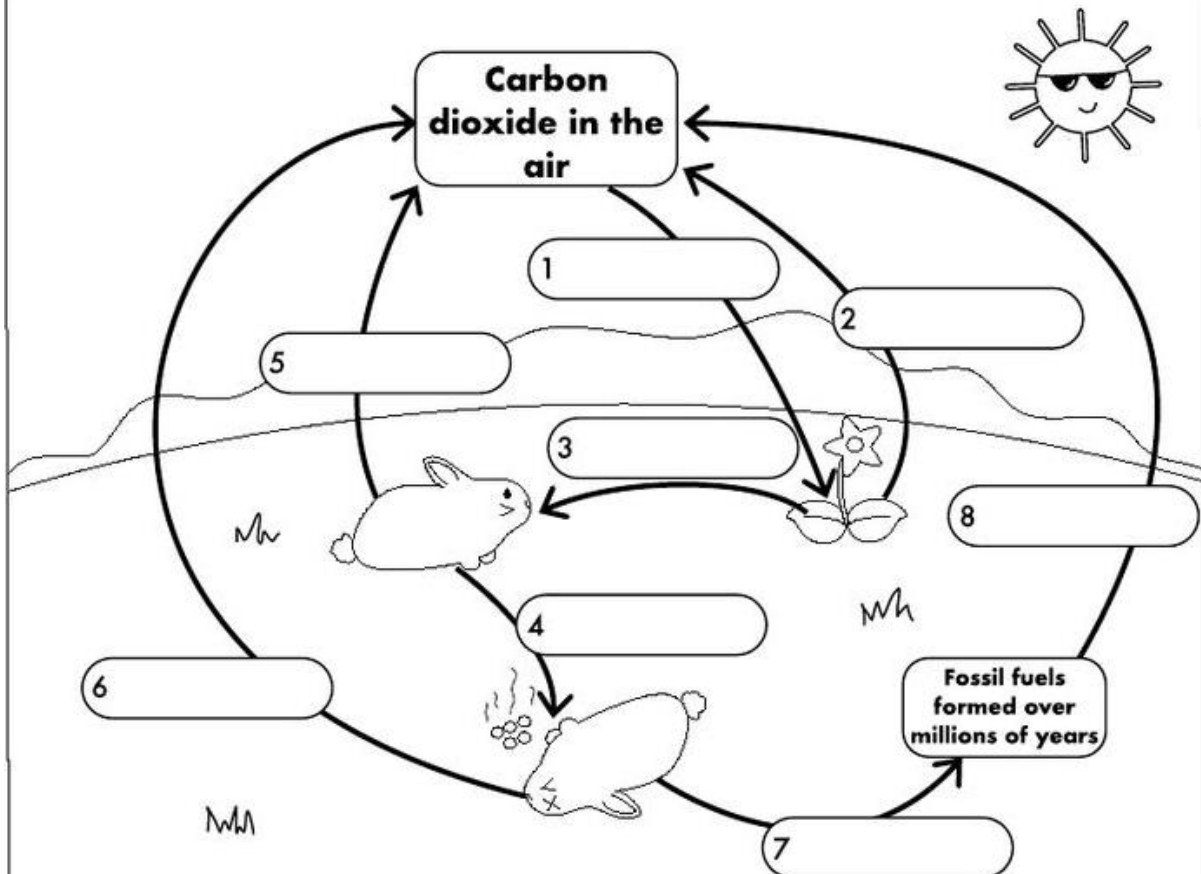

Key Points

- The carbon cycle involves the cycling of carbon between the environment and _____.
- Photosynthesis and _____ are the key processes involved in the cycle.
- Also decomposition which involves microorganisms called _____ is important to digest waste and dead organisms. These microorganisms are bacteria and _____.
- These decomposers carry out respiration, which converts _____ compounds in dead and waste material back to carbon _____ in the air.

Words to use

respiration dioxide
decomposers carbon
organisms fungi

Q.3

(10)

The Structure of DNA

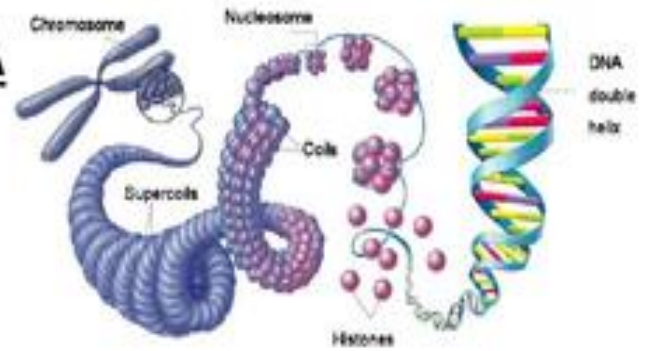

1. Why is the structure called a double helix?

2. Name the bases

3. List the base pairs

4. What is the backbone of DNA made from?

5. What is a nucleotide?

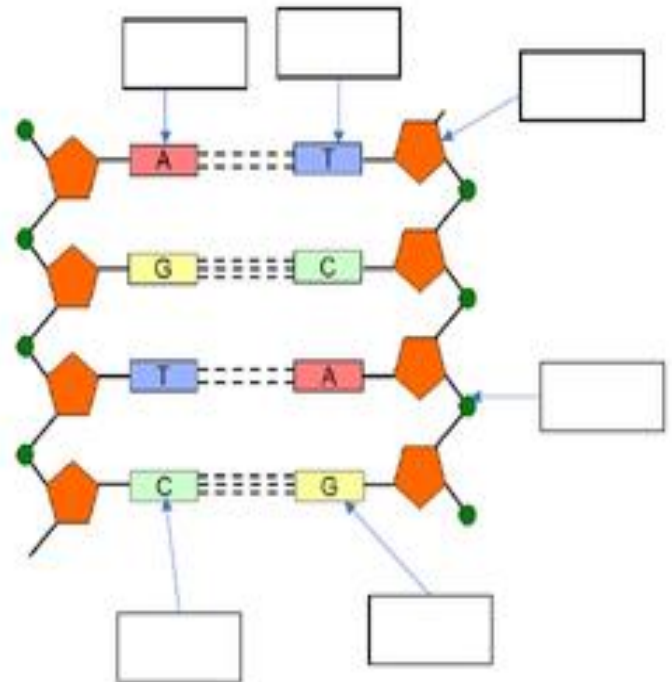

Q.4

(10)

ELECTRICITY AND MAGNETISM

1. Electrical energy carried by the parts of an atom
2. A material that allows electrons to move along it easily
3. The flow of electrons
4. A material that does not allow electrons to move along it easily
5. The path of an electric current
6. A circuit with only one path for electric current
7. A circuit with more than one path for electric current
8. The power of a magnet to attract objects made of iron and other metals
9. The space around a magnet where magnetism works
10. An object that becomes a magnet when electricity passes through it

- A. SERIES CIRCUIT
- B. ELECTROMAGNET
- C. CIRCUIT
- D. CHARGE
- E. PARALLEL CIRCUIT
- F. CONDUCTOR
- G. INSULATOR
- H. CURRENT
- I. MAGNETIC FIELD
- J. MAGNETISM

PERIODIC TABLE FACTS

- 1 Horizontal rows are called _____.
- 2 Vertical columns are called _____.
- 3 Elements in the same _____ have similar properties.
- 4 Elements belonging to the same family have the same number of _____ electrons.
- 5 Which element in Period 2 has the least mass? _____
- 6 Which element in Period 2 has the most mass? _____
- 7 To which group/family does each of these belong?
 - (A) Sulfur _____
 - (B) Sodium _____
 - (C) Argon _____
 - (D) Silicon _____
 - (E) Chlorine _____
 - (F) Phosphorous _____
- 8 The symbol for iron is Fe. Find iron in the periodic table and answer the following questions.
 - (A) What is the atomic number of iron? _____
 - (B) To which period does iron belong? _____
 - (C) To which group does iron belong? _____
 - (D) Name the elements that have properties like iron.

Note: Attempt all questions

Q1: Find the square of the following with the help of formula.

a) $2a + 1$

b) $3x - 4x$

Q2: Find the area and circumference of circle if the radius of the circle is 49 cm.

Q3: Construct the triangle from the following

$m\overline{AB} = 6 \text{ cm}$, $m\overline{BC} = 9 \text{ cm}$ and $\angle C = 60^\circ$.

Q4: Find the mean, median and mode of the given data

23,21,31,20,27,25,27,24,30,31,32

Q5: Find the value of x in the following

a) $2x - 7 = 0$

b) $8x - 7 = 5 + 5x$

c) $2(x - 1) + 2 = 12$

Q6: How much Zakat should be paid on yearly savings of Rs. 93800?

Q7: If 8 men can do a job in 2 days, how long will 24 men take to complete it?

Note: Practice all the exercises on your copy and submit it along with your vacation home work

Q1. convert into binary:

a. 48

b. 87

Q2. convert into decimal:

a. (101101)

Q3. subtract

$(110010) - (100101)$

Q4. Write an algorithm that compare 2 values also draw flow chart in MS WORLD

Q5. Create a presentation on "Climate Change"?

Q.1. Write a story with the help of following outlines. Don't forget to add elements of a story. Plot and Setting hints are already given in the table. Also give a suitable title and moral of your story.

Here are outlines to help you on your treasure hunt:

- i. Follow the river's frozen path to uncover a hidden entrance.
- ii. Keep an eye out for the tracks of a white fox, they'll guide you in the right direction.
- iii. Look for a tall pine tree standing alone near the tallest peak, it holds a clue.
- iv. When the moonlight reflects on the frozen lake, search for a special rock that shines.
- v. Navigate through the snowy maze and find a hidden cave where the treasure awaits.

Plot hints	Setting hints
Quest	Snowy
Mystery	Wilderness
Survival	Frozen
Friendship	Adventure
Discovery	Hunt

Q.2. Master phrases, improve communication.

(a) Noun Phrases

Instructions: Fill in the blanks with appropriate noun phrase.

- i. She packed her _____ with _____ for the trip.
- ii. The cat curled up on the _____, enjoying its _____ nap.
- iii. He bought a _____ to capture _____ moments on his travels.
- iv. They attended a _____, _____ and _____ to their favorite songs.
- v. The students gathered in the _____, studying for their _____ exams.

(b) Verb Phrases

Instructions: Fill in the blanks with appropriate verb phrase.

- i. She _____ the book on the shelf and walked away.
- ii. The cat _____ its kittens, ensuring their safety.
- iii. He _____ the meeting, realizing it wasn't necessary.
- iv. They _____ the tent and prepared for a camping trip.
- v. The students _____ into groups, working on different projects.

Q.3 (a) Synonyms and Antonyms

Instruction: Find the Synonym or antonym for the bolded word in each sentence.

- i. I love to **explore** new places, but I _____ to explore new things.
- ii. She is always **cheerful**, but her brother is quite _____.
- iii. The weather is **scorching** hot today, but tomorrow it's expected to be _____.
- iv. The movie was **incredibly** thrilling, but the sequel was rather _____.
- v. I find painting to be **relaxing**, but I find drawing _____.

(b) Homophones

Instructions: Choose the correct homophone from the parentheses to complete each sentence correctly.

- i. Can you (**see/sea**) the beautiful sunset?
- ii. She (**bought/bot**) a new dress for the party.
- iii. I need to (**write/right**) down this important information.
- iv. The cat chased the (**mice/might**) around the yard.
- v. He plays the guitar with great (**skill/scale**).
- vi. The students had to (**read/red**) the assigned chapter for homework.
- vii. The (**weather/whether**) is nice, so we can have a picnic.
- viii. She (**knew/new**) the answer to the math problem.

- ix. The baby took her first (**step/steppe**) today!
- x. Can you (**hear/here**) the birds singing in the morning?

Q.4 Practicing grammar and Punctuations.

(a) Verb Tenses

Instructions: Fix the verb tense errors by identifying and changing them to the correct tense.

- i. I go to the store yesterday.
- ii. She will cooks dinner tonight.
- iii. They have went to the party last night.
- iv. He did not knew the answer to the question.
- v. We are seeing a movie tomorrow.

(b) Possessive Pronoun and Possessive Adjective

Possession

It refers to the relationship between a noun and something that belongs to or is associated with that noun. It indicates ownership or control over something.

1	2	3	4
This	is	my your our their Mary's David's Mr. Brown's the doctor's his her	house. tin of petrol. bottle of ink. classroom. garden. goat. cow. coat. bedroom. watch. motorcar. bus.
That	is not		

Instructions: Read the table carefully and answer the questions given at the end.

Exercise:

- i. Read all the sentences, making different combinations. Write five sentences of possessive pronoun and five of possessive adjectives.
- ii. Turn the sentences into questions, like this:
Is that David's bottle of ink?
Now make any five questions yourself.

(c) Punctuations

Apostrophes and Hyphens:

Instructions: Insert the appropriate apostrophes or hyphens in the given sentences.

- i. The cats meow is music to my ears.
- ii. The well-known actor stole the show with his one liner.
- iii. We had a heart to heart conversation about our feelings.
- iv. The three-year-old child's laughter filled the room.
- v. She's the go to person for all your fashion advice.

(d) Colons and Semicolons:

Instructions: Use colons and semicolons in the following sentences where necessary.

- i. I have a favorite fruit. It's watermelon. It's so refreshing on a hot summer day.
- ii. She had a dilemma: stay at home and study for the exam or go out with her friends.
- iii. The recipe called for three ingredients: flour, sugar, and butter. It was simple yet delicious.
- iv. He had a habit of procrastinating, and it always resulted in last-minute stress.
- v. The meeting is scheduled for tomorrow at 2:00 PM. Please make sure to be on time.

Q.5. Essay Writing Task: Persuasive Essay

Instructions: Write persuasive essay on the following topic.

Your essay should have an introduction, body paragraphs, and a conclusion. Use proper paragraphing and provide details and examples to support your ideas.

Topic: The Importance of Teaching financial Literacy in School

Imagine your cousin has graduated high school and he always struggled to manage his/her personal finances for college. By highlighting the challenges faced by your cousin and the benefits of financial literacy education, you can emphasize the need for schools to provide students with the skills to make informed financial decisions.

Consider the following questions to help you develop your essay:

- i. Why is it important for schools to teach students about managing money?
- ii. What are some basic financial skills that students should learn in school?
- iii. How can understanding financial concepts help students in their everyday lives?
- iv. What are the potential consequences of not having financial literacy education in schools?
- v. How can financial literacy education help students achieve their long-term financial goals?

Remember to organize your essay into paragraphs, use proper grammar and punctuation, and provide strong arguments. Aim to make your essay clear and coherent, ensuring that your ideas flow logically from one paragraph to another.

Note: In persuasive essay, you'll need to present strong arguments and evidence to support your viewpoint.

Spelling Bee List

Aardvark	Kumquat	Photosynthesis	Astrionics	Stethoscope
Armadillo	Lychee	Thermodynamics	Aeronautics	Scrubs
Chameleon	Mangosteen	Augmented Reality	Geostationary	Combat
Chimpanzee	Physalis	Artificial Intelligence	Hypoxia	Commemorate
Hippopotamus	Persimmon	Bio mechatronics	Hypersonic	Constantinople
Komodo Dragon	Pomelo	Cryptocurrency	Propulsion	Dejected
Octopus	Rambuta	Cryptanalysis	Rocket	Dilapidated
Narwhal	Strawberry	Cybersecurity	Satellite	Exasperated

Penguin	Biotechnology	Encryption	Supersonic	Escapologist
Platypus	Chromosome	Gadget	Thermosphere	Incandescent
Peregrine Falcon	Chromatography	Malware	Anesthesiologist	Malevolent
Quokka	Condensation	Nano technology	Cardiology	Oblivion
Rhinoceros	Electromagnetism	Plagiarism	Dermatology	Phantasmic
Rattle snake	Hypothesis	Quantum mechanics	Gynecology	Painstakingly
Ackee	Mitochondria	Robotics	Gastroenterologist	Tantrum
Avocado	Meteorology	Virtualization	Hematology	Tormented
Broccoli	Microorganisms	Aerodynamics	Neurology	Chthonic
Durian	Ornithology	Astronomical	Orthopedics	Pneumonia
Guava	Ophthalmology	Avionics	Ophthalmologist	Subtle
Jack fruit	Paleontology	Astronautic	Radiology	Worcestershire

Archipelago	Exponentiation	Supernova	Lycopodium	Sapphire
Biome	Fractal	Ubiquitous	Maple	Tanzanite
Continent	Logarithm	Amethyst	Orchid	Zircon
Cartography	Multiplication	Blue	Pothos	Zoisite
Cryosphere	Quadratic	Coral	Poinsettia	Australia
Glacial	Subtraction	Cerulean	Snake plan	Canada
Hydrosphere	Trigonometry	Cyan	Sun flower	Czech Republic
Latitude	Transcendental	Eccentric cerulean	Titan arum	Djibouti
Lithosphere	Black hole	Indigo	Venus flytrap	Kazakhstan
Oronym	Celestial	Lavender	Welwitschia mirabilis	Kyrgyzstan
Orogenesis	Dark matter	Maroon	Alexandrite	Luxembourg
Orogeny	Esoteric	Magenta	Azurite	Mauritius

Permafrost	Luminous	Periwinkle	Benitoite	Netherland
Topography	Nebulae	Teal	Citrine	Philippine
Addition	Obfuscate	Turquoise	Emerald	Paraguay
Algorithm	Planets	Vermilion	Hematite	Uzbekistan
Calculus	Pulsar	Allium cepa	Labradorite	Debris
Conjecture	Quasar	Corpse flower	Moonstone	Knead
Differential	Stars	Carnation	Pietersite	Psychology
Division	Super massive	Fern	Sphalerite	Salmon

Class: 7th

Subject: History and Geography of Pakistan

1. Make a timeline of Prime Ministers of Pakistan from (1947-2022), also mention their political affiliation and terms.
2. What was Pakistan resolution? When did it pass and what happened on that day?
3. Find about 3rd June plan? Explain the division plan of subcontinent?
4. Compare the differences and similarities of the three constitutions of Pakistan.
5. Write any five major initial problems of Pakistan.
6. Identify the borders of Pakistan on Asian map and explain its geographical importance.

ماڈرن ایجوکیشن سکول وکالج ایبٹ آباد
مضمون: اردو

چھٹیوں کا کام

جماعت: ہفتم

سوال 1- درج ذیل عنوان پر مضمون تحریر کریں۔

ب۔ وطن سے محبت ایک فطری جذبہ ہے

ا۔ نظم و ضبط

سوال 2- درج ذیل عنوان پر طبع ذاد کہانیاں تحریر کریں۔

ب۔ نیکی کا صلہ

ا۔ پرندوں کا ظالم شکاری

نوٹ۔ طبع ذاد کہانی سے مراد خود کہانی بنانا اور تحریر کرنا۔ طلباء اپنی بنائی ہوئی کہانی تحریر کریں۔

سوال 3- اپنے اور اپنے دوست کے درمیان کھیلوں کی اہمیت پر مکالمہ تحریر کریں۔

سوال 4۔ دلچسپ سفر پر روداد تحریر کریں۔

سوال 5۔ اپنے دوست کو موسم سرما کی چھٹیاں اپنے گھر میں گزارنے کی دعوت کا خط تحریر کریں۔

سوال 6۔ میونسپل کمیٹی کے چیئرمین کو محلہ کی صفائی کی درخواست تحریر کریں۔

سوال 7۔ اپنی جیب خرچ سے کوئی ناول یا کہانی کی کتاب خریدیں اور پڑھیں۔ پڑھائی کے بعد کتاب کے متعلق اپنے تاثرات تین بیرو گراف میں لکھیں۔

نوٹ۔ کتابوں سے دوستی آپ کو کامیاب انسان بنا سکتی ہے۔ اس لیے جتنا ہو سکے کتابیں پڑھیں اور خوش رہے۔

ماڈرن ایچ پبلک سکول و کالج ایبٹ آباد

جماعت: ہفتم

مضمون: اسلامیات اور مطالعہ قرآن

سوال نمبر 1۔ سورۃ الانفال میں سے 30 الفاظ معنی لکھیں۔

سوال نمبر 2۔ قصہ زکریا مختصر لکھیں۔

سوال نمبر 3۔ حدیث نمبر 1 تا 5 ترجمہ لکھیں۔

سوال نمبر 4۔ قرآن مجید کا تعارف لکھیں۔

سوال نمبر 5۔ وضو اور غسل کے فرائض لکھیں۔

نوٹ: لکھائی کا تمام کام زبانی یاد کریں۔