

**Modernage Public School & College Abbottabad,
Pakistan**

**Homework for Winter Break Class 7
Session 2024 – 25**

Dear Parents/Guardians Finally, Winter is here, signaling the end of the Academic session 2024 and start of a winter break. We take great pleasure in announcing the successful culmination of the academic session 2024. Observing the continuous development and advancement of your child has been a source of immense satisfaction. To foster ongoing engagement with education during the holiday period, we are providing a comprehensive work pack comprising a multitude of enjoyable tasks and intellectually stimulating activities. Thank you for being an integral partner in your child's education. We eagerly anticipate another year of mutual growth and learning.

Dear Modernites! Reflect on the achievements and lessons learned during the previous academic session. Complete the assigned exercises in your respective subjects, embracing the knowledge gained. Take a moment to chill and recharge during this winter break. Use the new year as a fresh start for academic goals and personal growth. Ensure neatness and organization in your work. We hope that you have cheerful and safe Winter vacation with your families. The school will remain closed for winter vacation from Saturday 21st December, 2024 till Sun 02nd March, 2025 and reopen on Mon 03rd March, 2025 In Sha Allah. Submit the completed assignment till 10th March 2025.

Looking forward to your cooperation.

A copy of this homework is also available at the official webpage www.maps.edu.pk, the portal and app of Modernage. Best Regards Academic Coordinator Happy New Year. Note: Certificates will be awarded for extra ordinary efforts and complete homework. Each task carries 10 marks. Please use loose sheets for your assignments.

Q.1

(10)

THE BRAIN

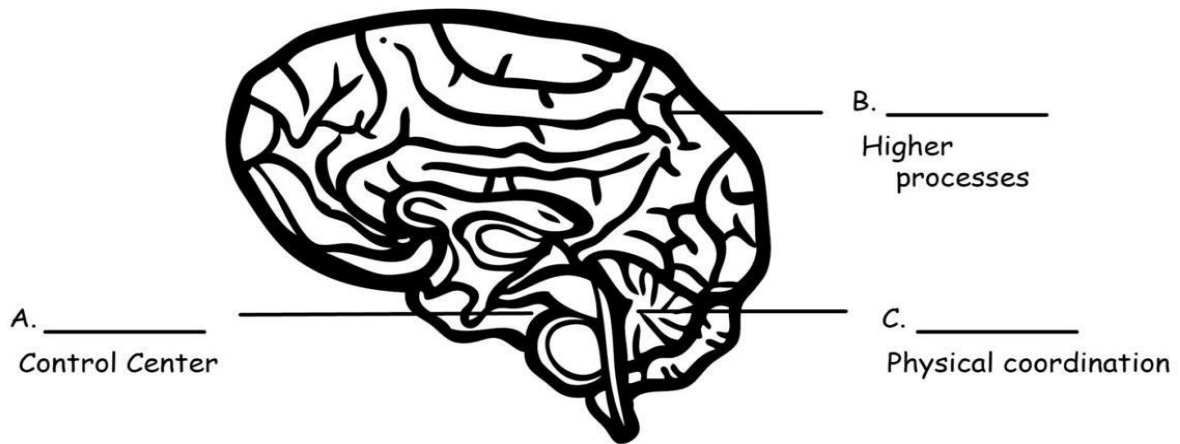

Identify the three major parts of the brain indicated on the diagram. Write the name of each part in the appropriate space on the diagram above and in the chart below. Briefly describe the function of each in the space indicated.

NAME	FUNCTION
A. _____	_____
B. _____	_____
C. _____	_____

Name the parts of the brain responsible for coordinating or controlling each activity or condition listed below.

NAME	FUNCTION
1. Tasting a hamburger	_____
2. Artistic ability	_____
3. Kicking a soccer ball	_____
4. Rate of breathing	_____
5. Tying your shoes	_____

Q.2

(10)

The Carbon Cycle

Label the numbered boxes correctly with the following:

Respiration by animals

Feeding

Decomposition

Death and waste

No decomposition

Combustion

Respiration by plants

Photosynthesis

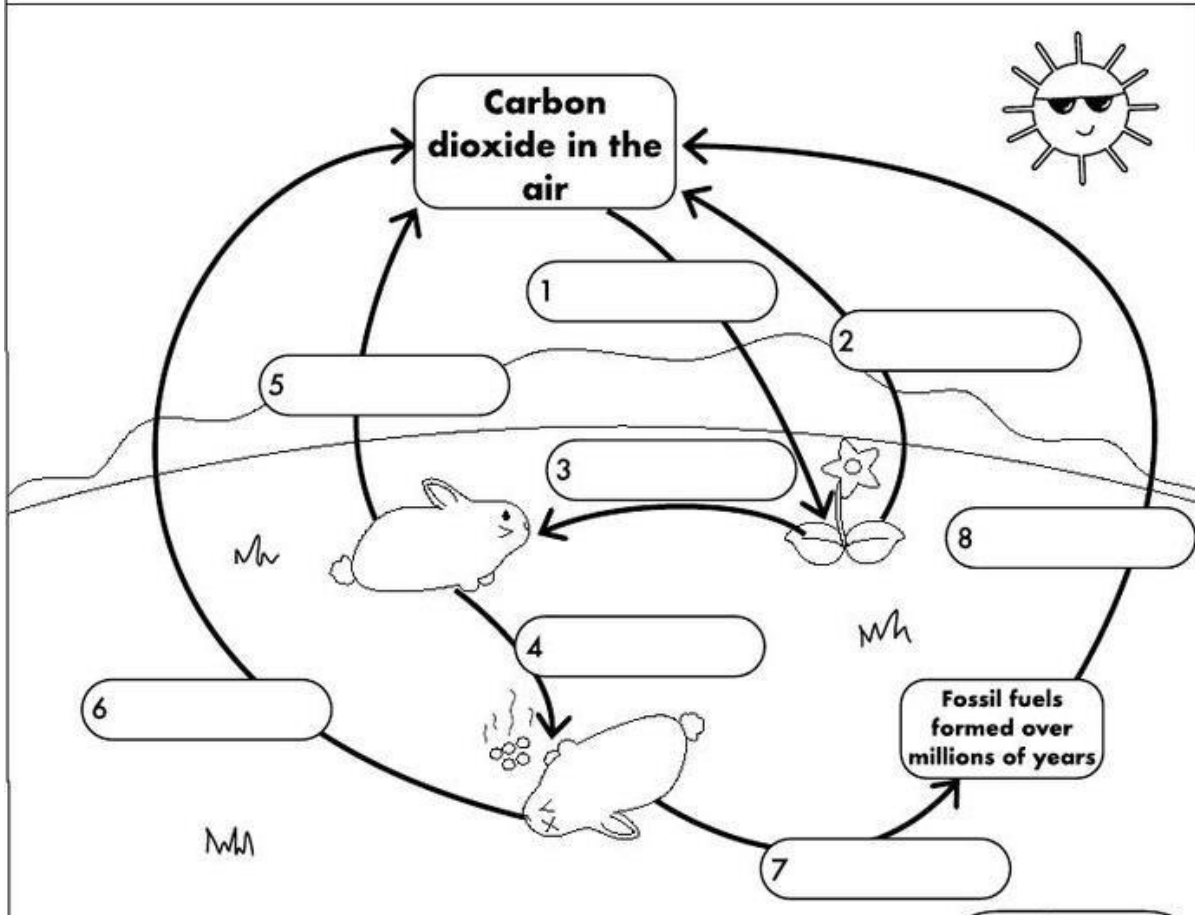

Key Points

- The carbon cycle involves the cycling of carbon between the environment and _____.
- Photosynthesis and _____ are the key processes involved in the cycle.
- Also decomposition which involves microorganisms called _____ is important to digest waste and dead organisms. These microorganisms are bacteria and _____.
- These decomposers carry out respiration, which converts _____ compounds in dead and waste material back to carbon _____ in the air.

Words to use

respiration dioxide
decomposers carbon
organisms fungi

Q.3

(10)

The Structure of DNA

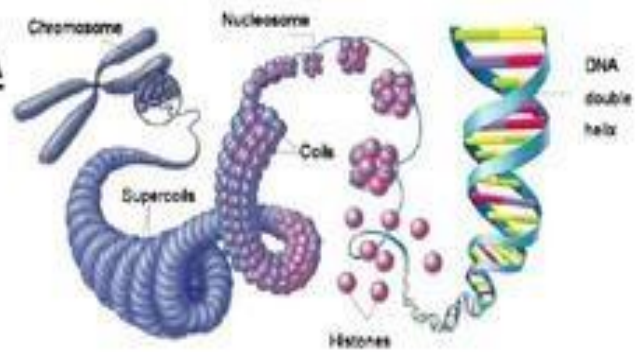

1. Why is the structure called a double helix?

2. Name the bases

3. List the base pairs

4. What is the backbone of DNA made from?

5. What is a nucleotide?

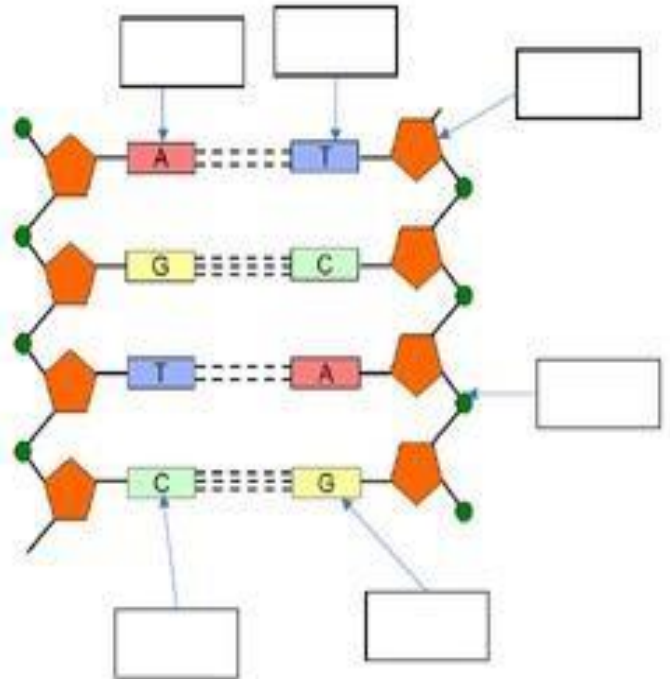

Q.4

(10)

ELECTRICITY AND MAGNETISM

1. Electrical energy carried by the parts of an atom
2. A material that allows electrons to move along it easily
3. The flow of electrons
4. A material that does not allow electrons to move along it easily
5. The path of an electric current
6. A circuit with only one path for electric current
7. A circuit with more than one path for electric current
8. The power of a magnet to attract objects made of iron and other metals
9. The space around a magnet where magnetism works
10. An object that becomes a magnet when electricity passes through it

- A. SERIES CIRCUIT
- B. ELECTROMAGNET
- C. CIRCUIT
- D. CHARGE
- E. PARALLEL CIRCUIT
- F. CONDUCTOR
- G. INSULATOR
- H. CURRENT
- I. MAGNETIC FIELD
- J. MAGNETISM

PERIODIC TABLE FACTS

- 1 Horizontal rows are called _____.
- 2 Vertical columns are called _____.
- 3 Elements in the same _____ have similar properties.
- 4 Elements belonging to the same family have the same number of _____ electrons.
- 5 Which element in Period 2 has the least mass? _____
- 6 Which element in Period 2 has the most mass? _____
- 7 To which group/family does each of these belong?
 - (A) Sulfur _____
 - (B) Sodium _____
 - (C) Argon _____
 - (D) Silicon _____
 - (E) Chlorine _____
 - (F) Phosphorous _____
- 8 The symbol for iron is Fe. Find iron in the periodic table and answer the following questions.
 - (A) What is the atomic number of iron? _____
 - (B) To which period does iron belong? _____
 - (C) To which group does iron belong? _____
 - (D) Name the elements that have properties like iron.

Note: Attempt all questions

Q1: Find the square of the following with the help of formula.

a) $2a + 1$

b) $3x - 4x$

Q2: Find the area and circumference of circle if the radius of the circle is 49 cm.

Q3: Construct the triangle from the following

$m\overline{AB} = 6$ cm, $m\overline{BC} = 9$ cm and $\angle C = 60^\circ$.

Q4: Find the mean, median and mode of the given data

23,21,31,20,27,25,27,24,30,31,32

Q5: Find the value of x in the following

a) $2x - 7 = 0$

b) $8x - 7 = 5 + 5x$

c) $2(x - 1) + 2 = 12$

Q6: How much Zakat should be paid on yearly savings of Rs. 93800?

Q7: If 8 men can do a job in 2 days, how long will 24 men take to complete it?

Note: Practice all the exercises on your copy and submit it along with your vacation home work

Computer

Class 7th

Q1. convert into binary:

a. 48

b. 87

Q2. convert into decimal:

a. (101101)

Q3. subtract

$(110010) - (100101)$

Q4. Write an algorithm that compare 2 values also draw flow chart in MS WORLD

Q5. Create a presentation on "Climate Change"?

Class 7th

English

English:

1. Reading: Reading Comprehension

i. Read the passage and answer the questions below.

Snow covered the small town like a soft blanket. The streets were silent except for the crunching sound of boots. Children gathered in the park, their laughter echoing as they built snowmen and slid down icy hills. Winter brought challenges, but it also brought joy and togetherness.

Questions:

1. What is the main theme of the passage?

2. Find and write two adjectives used to describe the town.

3. How do the children feel during winter? Provide evidence from the text.

4. Write a synonym for "challenges" and "joy."

ii. Read the short story below and answer the questions.

The Snowy Surprise

Emma woke up to a blanket of snow covering her small village. The trees sparkled like crystals, and the streets were silent. She and her brother, Jack, decided to build the biggest snowman the village had ever seen. As they worked, they found a shiny red box buried in the snow. Inside was a note that read, "To whoever finds this, spread joy!" Emma smiled and handed out cookies from her kitchen to everyone in the village. That winter became the most memorable one.

Questions:

1. What made the village look beautiful?
2. What did Emma and Jack find?
3. What lesson can we learn from this story?
4. Identify and write the direct speech from the story.
5. Draw and colour the underlined scenes or objects.

iii. Stanza Comprehension

Read the stanza below and answer the questions.

Snowflakes dancing, soft and white,
Cover the ground in the moon's pale light.
The world is quiet, calm, and still,
Winter whispers across the hill.

Questions:

1. What is the poet describing in the stanza?
2. Write two adjectives used in the stanza.
3. How does the poet describe the atmosphere in winter?
4. What literary device is used in "Winter whispers across the hill"?

2. Reading Adventure: A Journey Through Stories

- i. Read a storybook, novel, or a chapter from a famous book.
- ii. Write:
 - a) A brief summary (150-200 words).
 - b) Your favourite part of the story and why you liked it.
 - c) Five new words you learned, along with their meanings and sentences.

3. Writing: Unleash Your Imagination

Option 1: Write a diary entry about a perfect snowy day. Describe how you spent it, the people you were with, and how you felt.

Option 2: Write a short dialogue (150 words) between two friends about their plans for the winter holidays.

4. Grammar Challenge: Master Your Basics

- i. **Tenses Practice:** Write 3 sentences for each tense (present, past, future) in affirmative, negative, and question forms.
- ii. **Punctuation Practice:** Rewrite this passage by adding correct punctuation:
the snow fell softly outside the children were inside playing games suddenly there was a knock at the door who could it be they wondered

5. Listening and Speaking: Fun with Stories

- i. Watch an animated movie or a documentary in English.
- ii. Write 5 interesting phrases or sentences you hear.
- iii. Practice saying them aloud to improve your pronunciation.

6. Fun and Reflection Activity:

Part 1. Winter Memory Jar:

- i. Write down your happiest winter memory on a small piece of paper.
- ii. Decorate it and keep it safe to share with your class after the holidays!

Part 2. Winter Treasure Hunt

- i. Create a "Winter Memory Box."
- ii. Collect 5 items (photos, drawings, or small objects) that remind you of winter.
- iii. Write a sentence or two describing each item. Example: "This pinecone reminds me of the walks I took in the forest."

7. Poetry and Creativity

Task: Write a winter-themed acrostic poem using the word "WINTER."

- **Example:**
White snow falling all around,
Icy winds that softly sound,
Nights are cold, yet hearts are warm,
Together we face the storm.

8. Word Game Galore

Part 1: Word Scramble

Unscramble the winter-related words:

1. ONSWFLKEA (Hint: Falls from the sky)
2. FRIEPACL (Hint: Keeps you warm)
3. IMTNTSE (Hint: Worn on hands)

Part 2: Riddle Time

Solve these riddles:

1. I am white and cold, and I fall from the sky. What am I?
2. I am used to keep you warm. I have sleeves.

9. Letter Writing

Task: Write a letter to ChatGPT (or any AI assistant) describing what you love about winter and asking questions about how winter is experienced in other parts of the world.

What to Do:

1. **Begin your letter with the correct format:**
 - a) Your address (top right corner).
 - b) Date (below your address).
 - c) Greeting (e.g., Dear ChatGPT or Dear AI Assistant).
2. **In the body of your letter, include:**
 - a) An introduction: Who you are and why you are writing.
 - b) Describe what you love about winter (e.g., snow, warm clothes, holiday traditions).
 - c) Ask at least 2 questions about winter in other parts of the world. For example:
 - How do people celebrate winter in snowy countries?
 - What do you know about winter in hot climates?
 - d) Share a fun winter memory or activity you enjoy doing.
3. **End your letter with:**
 - a) A closing line (e.g., I hope you can answer my questions!).
 - b) Proper closing (e.g., Yours curiously, [Your Name]).

10. Rebus Story Creation

Task:

Create your own Rebus Story using pictures, symbols, and words. A Rebus is a fun way to tell a story using a combination of images and letters to represent words or parts of words. Follow the example below and then create your own!

Example Rebus Story:

Picture: 🗣️ 🖐️ 👣

Story (Hint):

"On a cold winter day, I went out for a walk and left footprints in the snow."

Instructions for Students:

1. Use a combination of pictures, symbols, and words to represent your own story. For example, you can use:

- i.  for tree
- ii.  for snow
- iii.  for gift
- iv.  for walking
- v.  for chocolate

Checklist for Story Creation:

- i. Use a mix of images and words to tell your story
- ii. Make sure your story is clear but challenging enough to be fun to decode.
- iii. After creating your rebus, write a short explanation of your story in words.

Class: 7th

Subject: History and Geography of Pakistan

1. Make a timeline of Prime Ministers of Pakistan from (1947-2022), also mention their political affiliation and terms.
2. What was Pakistan resolution? When did it pass and what happened on that day?
3. Find about 3rd June plan? Explain the division plan of subcontinent?
4. Compare the differences and similarities of the three constitutions of Pakistan.
5. Write any five major initial problems of Pakistan.
6. Identify the borders of Pakistan on Asian map and explain its geographical importance.

Subject: Urdu

Grade 7

سوال نمبر 1۔ آپ کا پسندیدہ سفر کون سا تھا، وہاں آپ نے کیا کیا دیکھا، کیا محسوس کیا؟ تفصیلاً تحریر کریں۔

سوال نمبر 2۔ نثر کی اقسام پڑھیں اور تعریفیں لکھیں۔

سوال نمبر 3۔ روزمرہ۔ محاورہ اور ضرب المثل کی تعریف اور فرق لکھیں۔

سوال نمبر 4۔ اخبار کے ایڈیٹر کو رپورٹر کی نوکری کے لئے درخواست تحریر کریں۔

سوال نمبر 5۔ انٹرنیٹ کے فائدے و نقصانات کا موازنہ کریں۔

سوال نمبر 6۔ علامہ محمد اقبال کے "5" اشعار بمعہ مفہوم تحریر کریں۔

سوال نمبر 7۔ تعلیم مکمل کرنے کے بعد آپ اپنے ملک کی خدمت کس شعبے میں رہ کر کرنا چاہیں گے۔ اپنے والد صاحب کے ساتھ مکالمہ کی صورت میں گفتگو کریں۔

س: پر امن زندگی گزارنے کے لیے اسلام کی پانچ تعلیمات بیان کریں۔

س: غزوہ خندق کی وجوہات تحریر کریں۔

س: مالِ غنیمت کیا ہے؟ یہ کن لوگوں کو دیا جاتا ہے؟

س: کسبِ حلال سے ہمیں کیا ثمرات حاصل ہوتے ہیں؟

س: سورت انفال کا ذہنی خاکہ بنائیں۔

س: بہترین ذکر کونسا ہے؟ اسکے دو فوائد تحریر کریں۔