



# MODERNAGE Public School & College, Pakistan

A Place to Flourish, Thrive & Shine



## Grade V

Summer Homework

[www.maps.edu.pk](http://www.maps.edu.pk)

## Dear Parents,

The moment children finish their First Term Exams, the most exciting and much awaited time of the school year i.e., the summer vacation starts the very next day.

Summer Vacations are greeted with joy by kids and are of course a time to reinvigorate and revive. However, a balance between recreation and work must be found to ensure a break that is productive as well as relaxing. As the school closes for the summer break, we have planned some activities / projects for your children to enhance their learning skills in a fun filled way. We have tried to make the work enjoyable keeping in mind the interest of the children, so that they are engaged positively and their energies are well-directed. Mentioned below tips will not only help your child stay organized but will also make your vacation fun-filled and interesting.

### Tips for Parents

There are many ways to support your child's learning by providing opportunities for reading, writing, speaking and listening while on vacation. Family discussions, word games, trips to a local bookstore or library to choose books, visiting museums and other interesting places are all fun ways to involve your child in literacy activities over the summer. As a parent, you must also promote physical activity, improve coordination, and teach good sportsmanship.

**HOLIDAYS HOMEWORK FOLDER:** Attempt all the activities/projects given in the Summer Vacation Task. Help your child make an attractive, handmade folder with old newspapers or charts. Decorate it and compile all the holiday homework in it. Looking forward to your cooperation.

Modernage wishes all of you happy and healthy Summer Vacation!

**Summer Vacations are starting from Thursday 25<sup>th</sup> June to Sunday 2<sup>nd</sup> August 2026.**

**School will reopen on Monday 3<sup>rd</sup> August 2026.**

### Follow these daily routines & Essential Values:

1. Listen when someone else is speaking.
2. Wake up early in the morning and offer prayer regularly and recite Holy Quran.
3. Take a bath daily.
4. Sweep or vacuum your room.
5. Help your mother lay out the table for meals.
6. Eat healthy food including fruits, vegetables, whole grains & drink plenty of water throughout the day to stay hydrated.
7. Wash your hands before taking food.
8. Treat others with respect.
9. Use a napkin and try not make a mess at meal times.
10. Schedule exercise or a walk for at least half an hour every day to become physically fit, strong & health.
11. Be the first to extend your greetings.
12. Limit screen time & promote outdoor activities.

- Q1. Select at least 50 words from unit:9 to unit 18 of English Book. Write their meanings and make sentences of 20 words of your choice
- Q2. How do you see the future? Write a short essay about it. Make sure the paragraphs are coherent and make sense. Use pronouns and transitional devices, such as, therefore, however, whereas, and for example.
- Q3. Write a formal letter to your principal about a fundraising.
- i. start and end the letter in the usual formal way. Include your own name and address, also the name of the principal to whom you are writing. Write the date too.
  - ii. Suggest a fundraiser. Suggest a charity that you would like to support. Why do you want to support this charity?
- Q4. The following is an outline of the story” The Mysterious Garden”. Write the whole story with the help of outline.

<b>Title</b>	<b>The Mysterious Garden</b>
<b>Characters</b>	Mother, Rohan(10 years old), Ali (Rohan’s Neighbour). Mrs. Qureshi(Ali’s Mom)
<b>Problems</b>	Rohan discovers a hidden, neglected garden in his neighborhood.
<b>Actions</b>	Rohan decides to clean up the garden with friends and Mrs. Qureshi’s guidance.
<b>End</b>	The garden is transformed, and the neighborhood comes together to enjoy it.

Q5. Read the given the poem" Houses" by Mary Britton Miller and answer the given Questions:

The homes of our Earliest ancestors Were lower than low. They had no windows; They had no doors. If you wish to go in You went on all fours. The dirt or the dust Or the snow was the floor. It was hundreds and hundreds Of years before Men lived in houses With windows and doors. Or lay down in beds Or sat up in chairs Or sat down at a table. Or walked upstairs:	Then as time goes It was no time at all Before houses were built. So exceedingly tall, They had hundreds of windows And only one door And you had to go up In an elevator And now they have grown So gigantically high They nudge the new moon And scrape the blue sky And today we live like bees in a hive In the tallest cities That Mister Man Has built on this earth Since the world began
---	--

**Questions:**

- i. How did people enter these early homes?
  - ii. What changes occurred in homes over hundreds of years?
  - iii. What feature do modern tall buildings have for easy access?
  - iv. What does the poet compare city dwellers to?
  - v. Who built the cities according to the poem?
  - vi. What are some features of your home that you like or find special?
  - vii. How is your home different from the homes of our earliest ancestors described in the poem?
  - viii. If you could design your dream home, what features would it have?
  - ix. How do you think life would be different if we still lived in homes without windows or doors?
  - x. Can you think of other ways human homes might change in the future?
- Q6. Read the following 10 books from Oxford Reading Buddy and attempt all the related quiz questions.
- |  |                              |
|--|------------------------------|
| i. How Rollright Got its Stones          | ii. How to Be a Tree         |
| iii. Animal Conflicts                    | iv. The Coaster- Roller      |
| v. Hercules the Hero                     | vi. Prince Razzle bag        |
| vii. The Foolish Hare and the Mango Tree | viii. We Want Change         |
| ix.. Tragic Legendary’s Heroes           | x.. Pirates of the Caribbean |

- Q1. Collect five different types of flowers. Observe which flowers have the sepals, petals, stamen and carpel and in which these are absent? Compare the structures in different flowers and record your observations in your homework folder.
- Q2. Construct a simple circuit using batteries, wires and bulbs to demonstrate how electricity flows and lights up a bulb. Explain the role of each component in the circuit.
- Q3. What are the differences between biodegradable and non-biodegradable materials, how do they affect the environment, and what are some ways to responsibly manage and reduce our use of both types of materials in our daily lives?
- Q4. Make a pinhole camera using instructions from page 66 of your General Science Book.
- Q5. Explore how light interacts with different objects! Design an experiment using various materials (e.g., glass, plastic, paper) and light sources (e.g., flashlights). Record and label how each object affects light passage. Present your findings in a diagram or drawing, showing which objects are transparent, translucent, or opaque.

**SOCIAL STUDIES**

- Q1. Collect pictures of different means of communication and make a collage. Write the names also.
- Q2. Make a small directory and write all the important emergency numbers in it.
- Q3. Make a model of an igloo with the help of cotton.
- Q4. Find out information about Death Valley, the driest place on the Earth.
- Q5. Make a small magazine of your own. Cut headings, pictures and news from different used newspapers.
- Q6. Which of the things in the pictures do you need? Which are nice to have but you don't really need? List them under the headings given below.

				
water	computer	shoes	pen	toys
				
food	watch	phone	sweets	a home
These are nice to have			I need these	

**MATHEMATICS****Q1. Solve the following.**

- 9 pens cost Rs 810, so 1 pen will cost Rs. \_\_\_\_\_
- Price of 7 flower pots = Rs 700  
Price of 1 flower pot = Rs \_\_\_\_\_  
Price of 9 flower pots = Rs \_\_\_\_\_
- Nida wants to plant 42 rose plants and 35 jasmine plants in her garden. What is the greatest possible number of rows if each row has same number of rose plants and same number of jasmine plants?
- Tom has 45 stickers and wants to share them equally among his 5 friends. How many stickers will each friend get?
- A bookshelf has 72 books on it, and they need to be packed into boxes that hold 9 books each. How many boxes are needed?
- A farmer has a rectangular plot of land that is 120 meters long. If the perimeter of the plot is 360 meters, what is the width of the plot? What is its area?

- v. A classroom floor is 8 meters long and has an area of 48 square meters. What is the width of the classroom floor? If they put tape around the edge of the floor, how much tape would they need?
- vi. A square-shaped garden has sides that are each 15 meters long. What is the perimeter of the garden? What is the area of the garden?
- vii. Emma is making a square picture frame. Each side of the frame is 12 inches long. How much wood does she need for the total frame (perimeter)? What is the area of the picture opening inside the frame?
- viii. The perimeter of a square park is 100 meters. What is the length of one side of the park? What is the area of the park?

**Q2. Find the cost of the following items.**

Item	Cost	Quantity	Total	Item	Cost	Quantity	Total
Apple	30	11	<input type="text"/>	Pencil	<input type="text"/>	5	165
Orange	<input type="text"/>	12	144	Pen	30	11	<input type="text"/>
Mangoes	50	5	<input type="text"/>	Ink	<input type="text"/>	2	120
Lychees	20	20	<input type="text"/>	Sharpener	25	<input type="text"/>	375
Cherries	30	<input type="text"/>	90	Eraser	<input type="text"/>	5	25
Bananas	<input type="text"/>	15	150	Notebook	90	3	<input type="text"/>

**Q3. Create your own colour code! On the chart, colour in multiples of 2, 3, 5 and 10. Use a different colour for each number.**

2

3

5

10

1	2	3	4	5	6	7	8	9	10
11	12	13	14	15	16	17	18	19	20
21	22	23	24	25	26	27	28	29	30
31	32	33	34	35	36	37	38	39	40
41	42	43	44	45	46	47	48	49	50
51	52	53	54	55	56	57	58	59	60
61	62	63	64	65	66	67	68	69	70
71	72	73	74	75	76	77	78	79	80
81	82	83	84	85	86	87	88	89	90
91	92	93	94	95	96	97	98	99	100

**Q4. Measure the following angles in the figure shown.**

- (a)  $m \angle AOB =$  \_\_\_\_\_
- (b)  $m \angle AOC =$  \_\_\_\_\_
- (c)  $m \angle AOD =$  \_\_\_\_\_
- (d)  $m \angle AOE =$  \_\_\_\_\_
- (e)  $m \angle BOC =$  \_\_\_\_\_
- (f)  $m \angle BOD =$  \_\_\_\_\_
- (g)  $m \angle BOE =$  \_\_\_\_\_

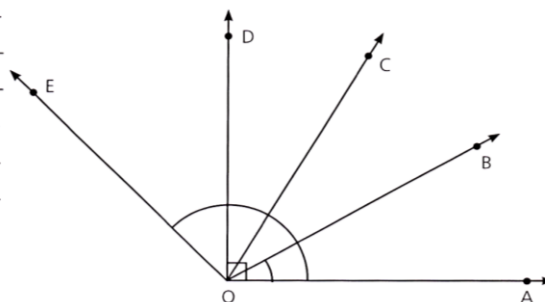

**Q5. Fraction Addition & Subtraction**

$$\frac{7}{8} + 4\frac{5}{8} =$$

$$16\frac{21}{22} - 7\frac{15}{22} =$$

$$13\frac{3}{10} - 6\frac{9}{10} =$$

$$19\frac{6}{17} + 28\frac{5}{17} =$$

$$4\frac{1}{6} + 35\frac{1}{6} =$$

$$62\frac{12}{19} - 7\frac{16}{19} =$$

## COMPUTER

Class 5

### 1. Design a Digital Greeting Card

Use **MS Paint**, **Tux Paint**, or **MS Word** to create a greeting card for one of these:

- Friendship Day
- Independence Day
- A friend's birthday

 Add colorful drawings, borders, and a short message.

 Save as: GreetingCard\_<yourname>.png or .docx

### 2. Design Your Dream Gadget

Use **MS Paint** or **Tux Paint** to draw your own invention:

- A homework robot
- A teleporting school bag
- A self-cooling water bottle

Then write 3–4 lines describing what it does using text tool.

 Save drawings as: DreamGadget\_<yourname>.png

### 3. Digital Travel Diary

Create a mini travel diary in **MS Word**.

- Add a photo (or draw) of a place you visited (real or imaginary)
- Write what you saw, ate, and enjoyed
- Use colors and bullets to make it neat

 Save as: TravelDiary\_<yourname>.docx

### 4. In MS Word, write a short paragraph explaining:

- What is a desktop background?
- What is a screen saver?
- How are they different?

 Save as: WallpaperVsScreensaver.docx

- ۱۔ کسی سفر کا مختصر احوال لکھیے۔
- ۲۔ اپنے دوست کے نام ایک خط لکھیں اور اپنی کسی پسندیدہ شخصیت کے بارے میں بتائیں۔
- ۳۔ اپنی پسند کی کوئی کتاب پڑھ کر اس کے متعلق اپنی رائے دیں۔
- ۴۔ درج ذیل عنوانات پر تین پیرا گراف پر مشتمل مضمون لکھیں جس میں کم از کم دو محاورے بھی شامل ہوں۔
- 1: کھیلوں کی اہمیت
- 2: میرا پسندیدہ پیشہ اور معاشرے میں اس کی اہمیت
- ۵۔ روزانہ ایک صفحہ خوشخطی کریں۔

- سورۃ القریش ترجمہ کے ساتھ خوشخط کر کے لکھیں۔
- ۲۔ سیرت کی کسی کتاب سے غزوہ بدر میں صحابہ کرام رضی اللہ تعالیٰ عنہ کی جان نثاری کا کوئی واقعہ لکھیں۔
- ۳۔ اچھی اور بری عادات کی فہرست تیار کریں اور معاشرے پر بری عادات کے مرتب ہونے والے اثرات تحریر کریں۔
- ۴۔ مسجد نبوی کا ماڈل بنائیں یا پرانی اور نئی تصاویر اکٹھی کر کے فضائل اور اہمیت لکھیں۔
- چار صوفیائے کرام رحمۃ اللہ علیہم کے بارے میں پانچ پانچ جملے لکھیں۔ اور ان کے مزاروں کی تصاویر چسپاں کریں۔

- Q1. Wax Painting: Draw a picture of your own choice by using different crayons.
- Q2. Leaf Impression & Colouring: Make your own picture frame by leaf impression and poster paints.